



DEVELOPMENT OF MEMBRANE REACTOR FOR HYDROGEN AND SYNTHESIS GAS CO-PRODUCTION

Markov A.A.^{1,2}, Merkulov O.V.^{1,2}, Patrakeev M.V.¹.

¹*Institute of Solid State Chemistry, UB RAS, 91 Pervomayskaya Str., 620990 Ekaterinburg, Russia, markov@ihim.uran.ru*

²*Institute of Solid State Chemistry and Mechanochemistry, SB RAS, Kutateladze 18, 630128, Novosibirsk, Russia*

Introduction

The importance of hydrogen as an energy carrier and a raw material for the chemical industry is growing rapidly, initiating the development of new methods for its production. Recently, different ways of hydrogen generation based on water splitting have drawn increased attention [1,2]. These methods are attractive because water is an inexhaustible resource, and hydrogen obtained from water is originally clean, in contrast to that traditionally produced by steam conversion of methane. The most promising is the combination in a membrane reactor of water splitting (WS) and partial oxidation of methane (POM) for simultaneous production of hydrogen and synthesis gas, respectively.

[1] S.K. Saraswat, D.D. Rodene, R.B. Gupta, *Renew. Sust. Energ. Rev.*, 2018, 89, 228–248.

[2] Y. Zhang, S. Kumar, F. Marken, M. Krasny, E. Roake, S. Eslava, S. Dunn, E.D. Como, C.R. Bowen, *Nano Energy*, 2019, 58, 183–19.

XXIV International Conference on Chemical Reactors CHEMREACTOR-24
September 12 - 17, 2021



Hydrogen Production by Water Splitting with MIEC Membrane

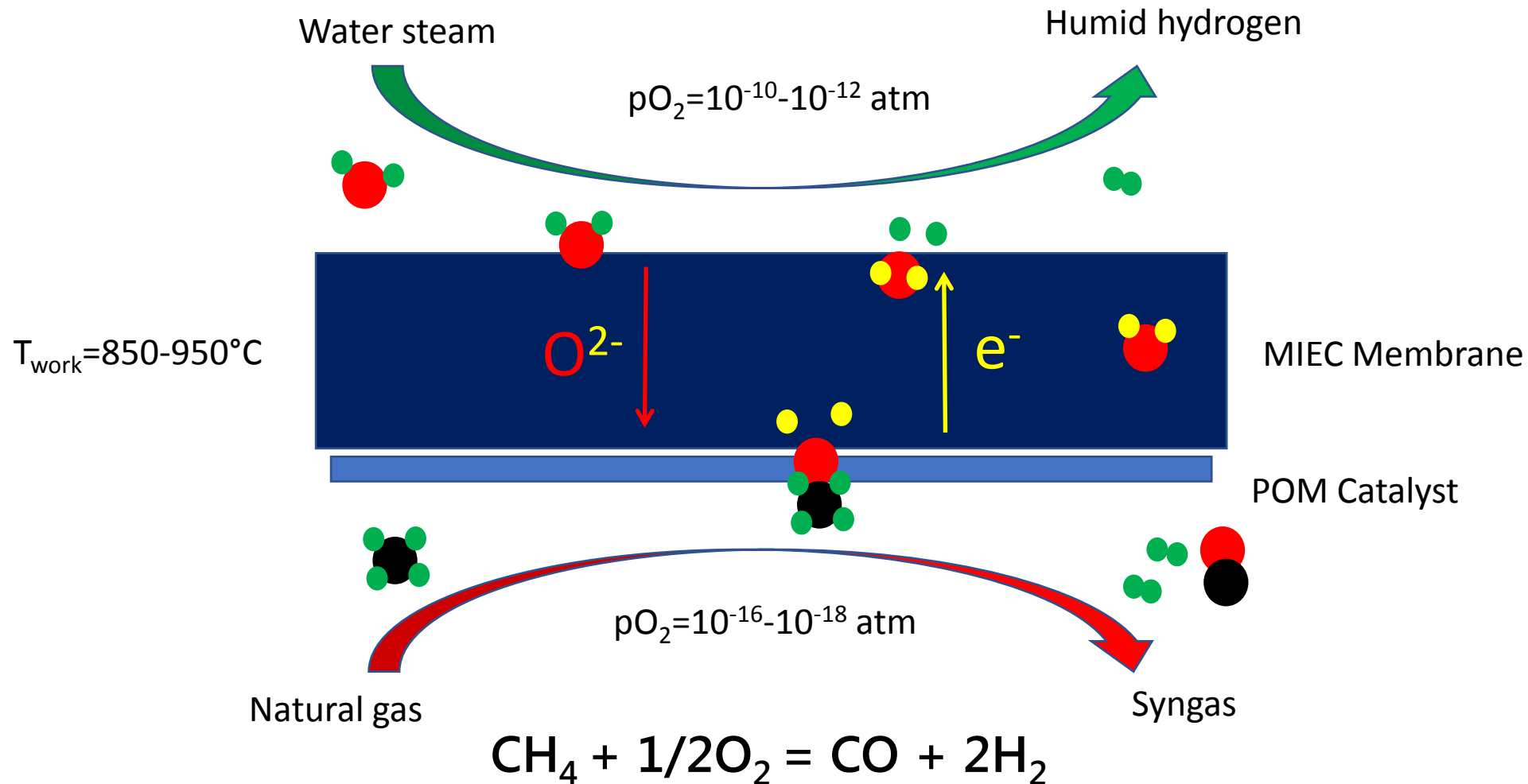
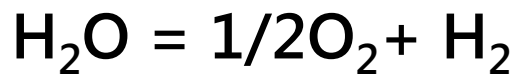

$$X_{\text{CH}_4} = \left(1 - \frac{x_{\text{CH}_4}}{x_{\text{CO}} + x_{\text{CO}_2} + x_{\text{CH}_4}} \right) \cdot 100\%$$

$$S_{\text{CO}} = \left(\frac{x_{\text{CO}}}{x_{\text{CO}} + x_{\text{CO}_2}} \right) \cdot 100\%$$

$$F_{\text{O}_2} = F_{\text{SG}} \cdot (1.5x_{\text{CO}} + 2x_{\text{CO}_2} + x_{\text{O}_2} - 0.5x_{\text{H}_2})$$

Based on volume concentrations of outlet sweep gas components, x_i , the POM process was characterized by conversion, X_{CH_4} , CO selectivity, S_{CO} , hydrogen to carbon monoxide ratio, H_2/CO , flux of the dry synthesis gas, F_{SG} , and oxygen separation flux

XXIV International Conference on Chemical Reactors CHEMREACTOR-24
September 12 - 17, 2021



Single-tube Reactor for Water Splitting and Partial Oxidation of Methane

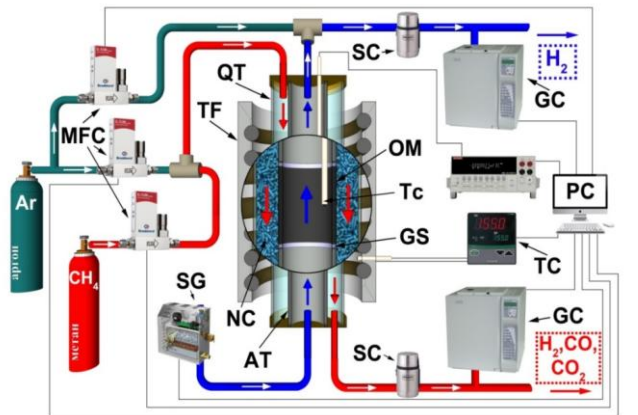

Scheme of experimental arrangement for ceramic membrane testing in a condition of simultaneous POM and WS processes. MFC - mass flow controllers, SG - steam generator, TF - tubular furnace, QT - quartz tube, NC - nickel catalyst, AT - alumina tube, SC - steam condenser, OM - oxygen membrane, T_c - thermocouple, GS - glass sealant, TC - temperature controller, GC - gas chromatograph, PC - personal computer

Membrane $\text{La}_{0.5}\text{Sr}_{0.5}\text{FeO}_{3-\delta}$
 $L=4\text{ cm}, D=1\text{ cm } T=900^\circ\text{C}$
 $F_{g\text{H}_2\text{O}} = 300\text{ ml/min}$



$K_{\text{CH}_4} > 99.8\%$ $j_{\text{H}_2} = 2.3\text{ ml}\cdot\text{cm}^{-2}\cdot\text{min}^{-1}$
 $C_{\text{H}_2} > 99.95\%$

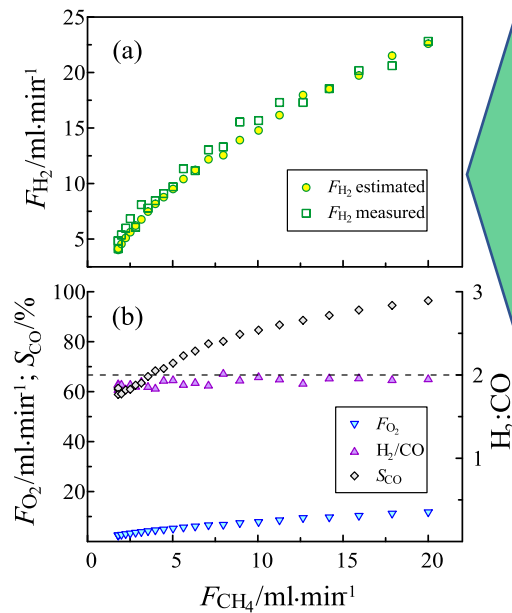
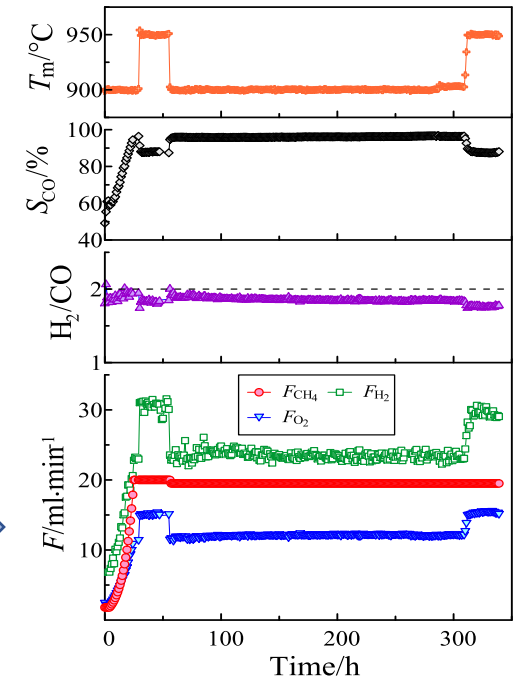

Figure presents the process parameters for water splitting (a) and partial oxidation of methane (b) simultaneously carried out in the laboratory membrane reactor. Methane conversion, which is not presented in the figure, was at least 99.8%. Yellow circles in Figure (a) designate values of hydrogen flux estimated from oxygen flux taking into account the materials balance requirement. Green squares in the same plot present measured values of hydrogen flux. Both sets of data are in reasonable agreement and show that hydrogen productivity of $2\text{ ml min}^{-1}\text{cm}^{-2}$ can be obtained on a 1-mm thick membrane of $\text{La}_{0.5}\text{Sr}_{0.5}\text{FeO}_{3-\delta}$ at 900°C . According to Figure (b), the measured ratio $\text{H}_2:\text{CO}$ does not exceed 2 even at selectivity of 96%, which is indicative of low probability for soot formation (SF) by methane dissociation

One can see that the ceramic membrane of $\text{La}_{0.5}\text{Sr}_{0.5}\text{FeO}_{3-\delta}$ provides an appreciable stability of the process characteristics in a stationary state at 900°C and in a reversible temperature change between 950°C and 900°C .





Multy-tube Reactor for Water Splitting and Partial Oxidation of Methane

The multi-tube reactor was designed with a radial methane feed for equal distribution of the load on the membranes

10 membranes $\text{La}_{0.5}\text{Sr}_{0.5}\text{FeO}_{3-\delta}$
L=5 cm, D=0.9cm, S=140 cm²
T = 900°C $F_{\text{gH}_2\text{O}} = 2 \text{ L/min}$

$K_{\text{CH}_4} > 99.5\%$ $j_{\text{H}_2} = 317 \text{ ml}\cdot\text{min}^{-1}$ $F_{\text{syngas}} = 571 \text{ ml}\cdot\text{min}^{-1}$

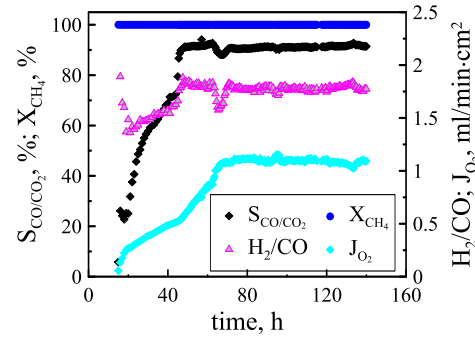
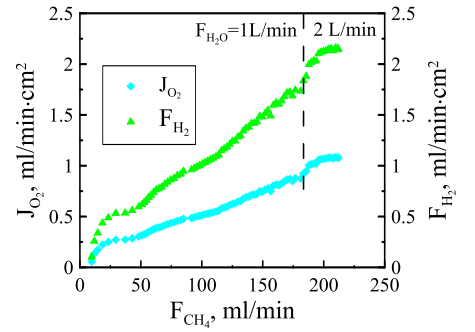
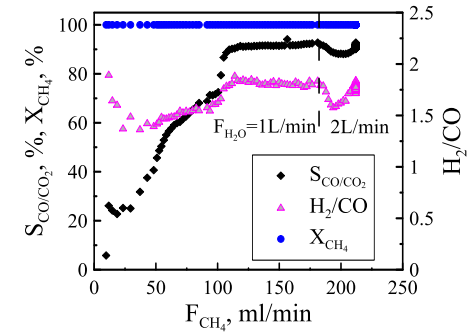
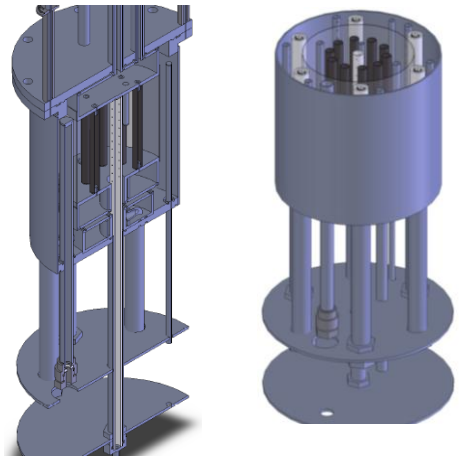

Results of testing the membrane reactor at 900 °C showed that the methane conversion in the process of partial oxidation was not less than 99.0%, at CO selectivity of 92%. The oxygen flow density reached 1 ml·min⁻¹·cm⁻². The specific hydrogen flux in accordance with the material balance conditions was ~2 ml·min⁻¹·cm⁻². A long-term stability test during more than 120 h showed the ceramic membrane of $\text{La}_{0.5}\text{Sr}_{0.5}\text{FeO}_{3-\delta}$ provides an appreciable stability of the process characteristics in a stationary state at 900 °C.

About 600 membranes are required to produce 1 m³/hour of pure hydrogen. To implement this technology, it is necessary to develop a new approach to the manufacture of membranes



Additive Technology for the Production of MIEC Membranes

The application of additive technology simplifies the process of manufacturing membranes with complicated shape

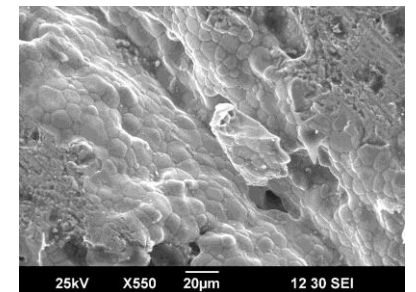
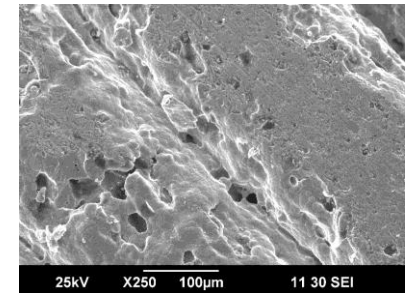
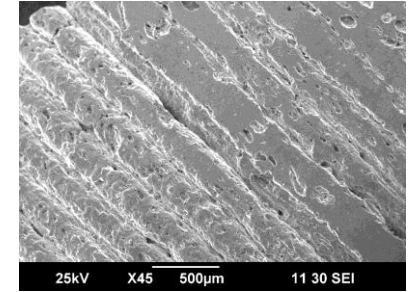
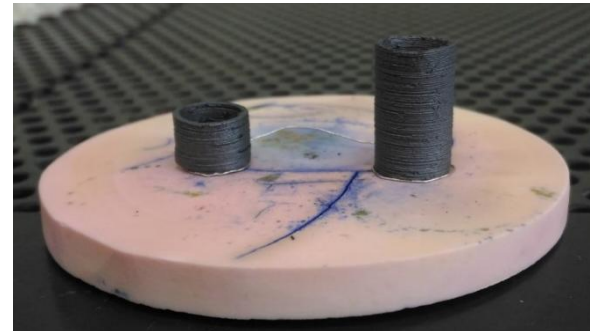
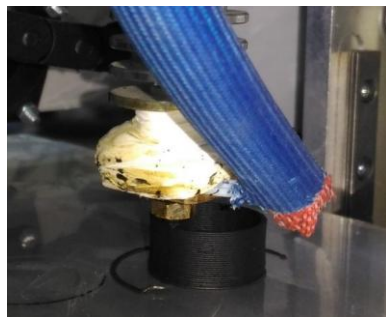
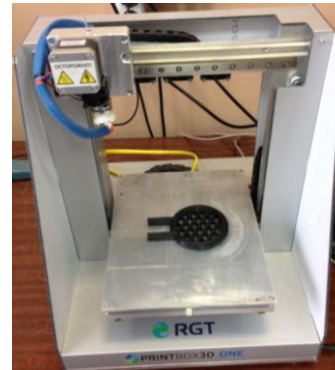
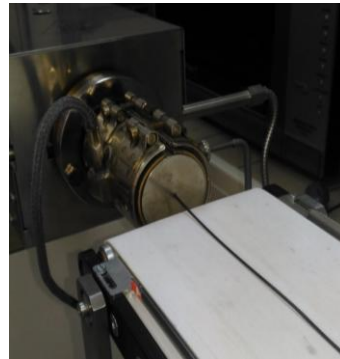
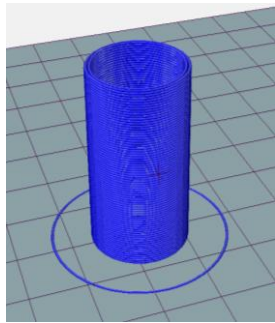
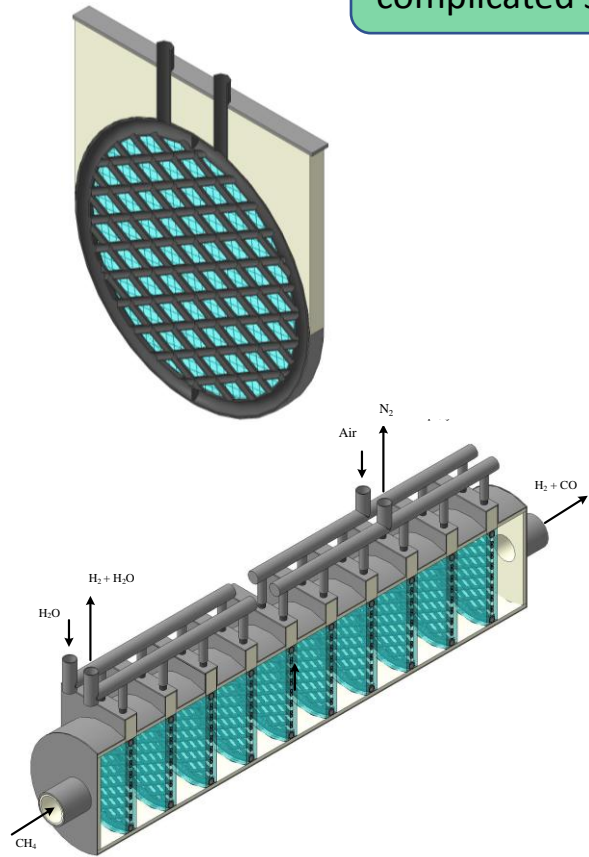



Conclusions

The tubular membranes of $\text{La}_{0.5}\text{Sr}_{0.5}\text{FeO}_{3-\delta}$ mixed conducting oxide was tested in a reactor combining partial methane oxidation and water splitting processes. Pure methane and steam were fed to the POM and SW compartments, respectively. This eliminated an interfering influence of ballast gases affecting the process characteristics and made it possible to reach methane conversion of about 99.5% at CO selectivity of 96%. No signs of difficulties associated with soot formation were observed.

Thanks for your attention

XXIV International Conference on Chemical Reactors CHEMREACTOR-24
September 12 - 17, 2021