

# Experimental studies of thermodynamic combustion processes of combustible demonstrators

**Yu Iordan**

Omsk State Technical University, Omsk, 644050, Russian Federation

**Abstract.** The description of experimental benches for combustion of demonstration elements of material samples - combustion demonstrators (CD) is given. CD for investigating thermodynamic processes during combustion on experimental benches are developed. The results of experimental studies of combustion of CD made of different materials (existing and synthesized) are presented. A new direction of research is formulated - the development of combustible materials and structures made of them, providing the specified characteristics at all stages of operation.

## 1. Introduction

Development of recyclable after fulfillment of its mission designs of items and their elements is currently an important and urgent task aimed at reducing the negative impact on the environment [1, 2]. Below we consider the utilization stage, which is the last stage of the product life cycle, by incineration of a separate class of items, such as separating parts of launch vehicles, in particular the payload fairing (PF). Creation of in-flight burned structures will make it possible to solve the problems of selecting drop zones for the separating parts of the launch vehicles, utilization of rocket armament samples after exercises, de-alerting, etc. In [3], a new approach to the design of an ultralight missile made of plastic, the body of which is a solid propellant charge and burns up in the process of launching the missile was proposed.

The studies of combustion of individual structural elements of launch vehicle parts, containers for petroleum products made of combustible materials revealed a number of problems associated with the materials used to make these elements [1, 4, 5]. In particular, experimental studies of the carbon fiber cladding element used on the PF found that under uniform thermal loading, when the temperature of  $\sim 4000\text{C}$  is reached, burnout of the epoxy binder in the sample is observed, and when  $\sim 12000\text{C}$  is reached, the carbon fibers of the sample are completely charred and the burnt sample almost completely loses its mass [5]. These experiments were conducted to determine the ignition and combustion temperature of the sample material without taking into account the real operating conditions of the structure (absence of an incoming aerodynamic flow, PF speed on the descent trajectory, and no heating time restrictions). According to the literature data, the maximum temperature during PF operation in the ascent phase is  $\sim 7000\text{C}$  in the tip area and decreases uniformly from the cone to the cylindrical part to a temperature of  $\sim 1000\text{C}$  [6].

Based on the studies, a new direction is formulated, which provides for the creation of materials, including their design, ensuring the possibility of subsequent utilization by combustion of structures made of them. The paper presents experimental studies of combustion of elements of a cylindrical part of a PF structure - combustible demonstrators (CD) made of different materials, both existing and synthesized. The experiments were carried out at the Institute of Problems of Chemical Physics of RAS,

the Institute of Solid State Chemistry and Mechanochemistry of SB RAS, the N.N. Semenov Federal Research Center for Chemical Physics of RAS and TSU Research Institute of Applied Mathematics and Mechanics.

In the existing PF design, the load-bearing layers are made of a polymeric composite material based on carbon fibers (carbon fiber reinforced plastic, CFRP) and a reinforcing aluminum honeycomb filler (ACF) [7] (Fig. 1).



**Figure 1.** Combustible demonstrator of sandwich design

## 2. Problem statement

1. Development of the program of experiments, which includes the purpose and objectives of the experiments; description of the CD and the materials from which they are made with justification for the choice of a particular composition; justification of the volume and number of experiments; the order of the experiment; measured parameters; justification of measuring instruments; description of the experiments and justification of the processing and analysis of results.

In accordance with the goal of combustion of CD under thermodynamic action, it is required to develop programs of experimental studies on several variants of bringing the CD material to the ignition temperature and subsequent combustion, which can be conditionally divided into two groups:

(a) Making changes to the existing design of the CD:

- Technology 1: placement of pyrotechnic composition (PC) in the cells of the ACF.
- Technology 2: application of the PC to the carrier layer, e.g. by means of adhesive compositions.

(b) Changing the CD materials and structures made of them:

- Technology 3: replacing the ACF material and structure with energy material (EM), including those based on mixed solid rocket fuel.
- Technology 4: replacement of the ACF material and design with energy material (EM) and replacement of the CFRP with another polymeric composite material.

2. Development of experimental benches including a heating element with a temperature-registering device, which is necessary to initiate a chemical reaction of combustion of PC or EM. To meet the safety requirements for the further combustion process of PC or EM due to the self-propagating high-temperature synthesis of the materials used. Ventilation to remove gaseous reaction products. Provide, if necessary, the specified velocity of the incoming flow and the possibility to conduct experiments at reduced pressure.

3. Development of combustible demonstrators, which are direct research objects and are samples of one- or three-layer PF shell design.

In the development of each of the above technologies it is necessary to select and develop materials and designs from them as follows:

- it is necessary to choose the type and parameters of materials, their composition and quantity in such a way as to ensure the conditions of temperature regime in the space under the fairing at the section of the takeoff until the moment of PF jettisoning in accordance with the requirements of the technical specification;
- parameters of the cladding design, filler, mass and distribution scheme of PC, EM shall be determined from the condition of preserving the specified strength requirements at the takeoff section and the conditions of combustion of the PF design when moving on the descent trajectory;

- evaluate possible design solutions, including possible materials, using as a prototype in terms of strength the ACF used;
- estimate the required mass of PC, EM to generate a given amount of heat during combustion required to heat the cladding to the ignition temperature and the subsequent combustion in the atmosphere;
- to minimize the mass of the structure.

### 3. Experimental studies of the combustible demonstrator

Let us consider the experimental studies of combustion of the PF design element in each direction.

#### 1. *Making changes to the existing design of the CD*

Making changes to the existing design involves increasing the weight of the structure, so when selecting a PC, it is necessary to ensure two conditions simultaneously: the maximum heat release at a minimum mass of the PC. Also, the combustion process should provide a self-sustaining mode and minimal gas generation during combustion.

The rationale for the choice of PC, options for their placement in the structure are described in papers [8-10]. Two types of PC were selected for experimental studies:

- Low-gas compositions based on a mixture of powders of active metals with oxides of less active metals ( $\text{Fe}_2\text{O}_3$ ,  $\text{CoO}$ ,  $\text{MnO}_2$ ,  $\text{V}_2\text{O}_5$ , etc.);
- Mixtures of two metal or metal-carbon powders capable of burning with the release of large amounts of heat without the formation of gaseous reaction products (e.g., mechanically activated PC  $\text{B}_4\text{C-4Ti}$ ).

The experiments were performed on single- and triplelayer CD at normal atmospheric pressure and diffusion oxygen inflow without taking into account the requirements of the mass ratio "CD-PC". The PC ignition process was initiated by a nichrome spiral at about 5V.

The pyrotechnic composition was placed in three-layer CD samples in powdered form (Technology 1), on single-layer CD samples in pasty and pressed form (Technology 2).

#### 2. *Changing the materials of the CD and structures made of them*

Proposals for replacement of CD design materials were made based on the results of experimental studies of Technologies 1 and 2. Technology 3 consists in replacing the ACF with a filler made of EM of various configurations. Since the filler in the three-layer PF structure plays the role of a supporting element, and the aluminum film has a minimum mass, when choosing the EM and the form of the filler, it is necessary to ensure the structural strength not lower than the existing one with a minimum deviation in mass (up to 5-10%).

Several types compositions of EM providing a self-sustaining combustion mode and their configurations were considered:

- Combustible energy material based on polylactide and ammonium perchlorate (35% PLA+65% PCA) made by 3D-printing in the form of a "gyroid" (Fig. 2). Experimental studies of combustion of this sample were carried out under aerodynamic blowing at a speed of 30 m/s.

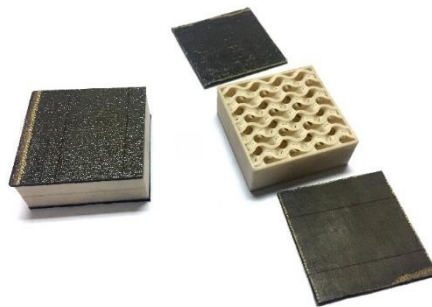

**Figure 2.** A sample of CD with an EM filler in the form of a "gyroid"

Experimental stand is a wind tunnel, which provides the necessary speed of aerodynamic flow on the CD, and includes a system of heating the blown sample with a nichrome spiral, powered from a

voltage not higher than 6-50 V AC or oxygen-propane mixture after a steady mode of the flow onset. In the course of the experiment the following parameters were recorded: temperature and velocity of the incoming flow, and surface temperature of the sample by means of thermocouple installation (Fig. 3).

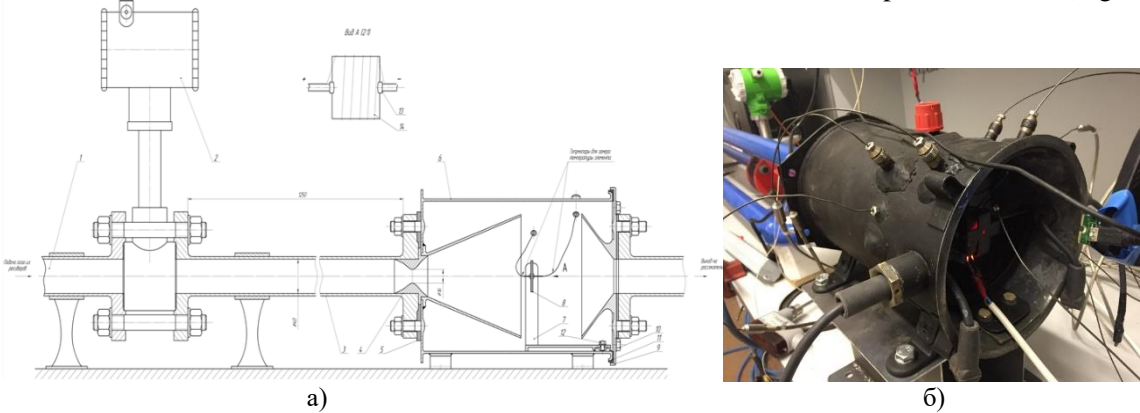

**Figure 3.** Experimental stand: a) fragment of the general view drawing; b) working part

b) Compositions based on mixed solid rocket fuel, where ammonium perchlorate ( $\text{NH}_4\text{ClO}_4$ ) or potassium perchlorate ( $\text{KClO}_4$ ) is used as oxidizer, aluminum powder is used as combustible and epoxy resin as fuel-binder. The type of the structure (rectangular channel, corrugation) and its geometrical parameters were determined based on the methodology [11-14]. The experimental samples are shown in Fig. 4.

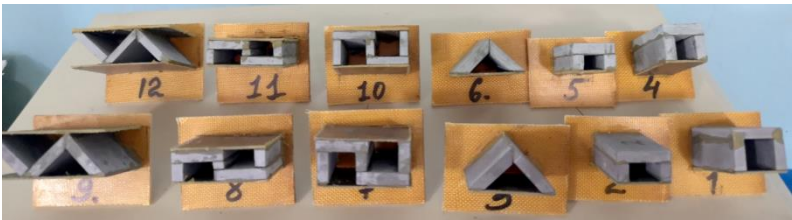

**Figure 4.** Samples of CD of different configurations with organoplastic skins

The scheme of the experimental bench is shown in Fig. 5. The CD under study is fixed on a tripod, the combustion process is initiated by a nichrome spiral. The combustion process temperature is measured with a pyrometer. A video camera is used to determine the combustion rate and video record the entire combustion process. The experimental bench also includes analytical scales to determine the percentage of cladding failure.

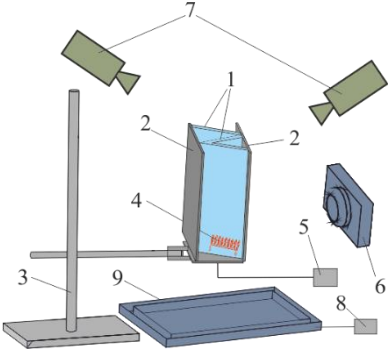

**Figure 5.** Schematic of an experimental stand: 1 - EM filler, 2 - load-bearing layers, 3 - tripod, 4 - glow spiral, 5 - power supply, 6 - pyrometer, 7 - video camera, 8 - scales, 9 - asbocardboard tray

Experiments with this type of filler were carried out including Technology 4. Polymeric composite materials based on thermoplastics, fluoroplastics and organoplastics were considered as the load-bearing layers material [15]. Organoplastic was used in the experiments.

#### 4. Results and discussion

As a result of the experimental studies according to Technologies 1 and 2 it was possible to achieve dispersion of the carbon fiber cladding and complete burnout of the ACF (Fig. 6, 7). However, in order to achieve such a result, the PC mass must exceed the established limits by several times. The presented results were the basis for consideration of the options for substitution of structural materials.



**Figure 6.** Results of CD combustion (Technology 1)

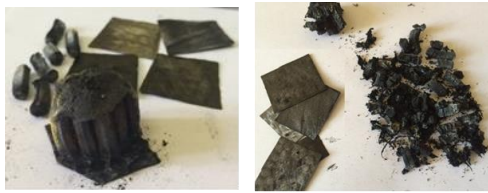

**Figure 7.** Results of CD combustion (Technology 2)

Experimental studies on Technology 3 (a) showed that during combustion in the gas flow, there is an acceleration of the intensity of the combustion reaction. At the same time, the heat released during the combustion of the filler is carried away by the oncoming flow, so that the carbon fiber reinforcement remains unchanged (Fig. 8).



**Figure 8.** Results of CD combustion (Technology 3)

The complete replacement of the construction materials (Technology 4) leads to a weight loss of up to 60-70%, while ensuring the specified strength of the structure (Fig. 9).



**Figure 9.** Results of CD combustion (Technology 4)

Based on the above studies, we can conclude that the currently used polymeric composite materials, of which the elements of launch vehicle parts are made, have overstated characteristics. Therefore, the task of developing a new combustible polymeric composite material and structures made of it, which provides the specified thermal strength characteristics in the atmospheric section of the launch vehicle trajectory and is recyclable on the descent trajectory, is relevant.

## 5. Conclusion

1. The program of experiments, requirements for experimental samples and test benches were developed.
2. Demonstration elements of material samples on the example of **PF** for their combustion on special experimental benches were developed.
3. The developed experimental programs, experimental specimens for combustion, experimental benches with equipment for registration of combustion processes are scientifically new; they are the initial provisions for the following developments of materials and structures utilized by combustion method.
4. The studies conducted have shown that there is a wide range of constructions, which are appropriate to utilize by incineration. The given example with **PF** is one of the variants of realization of a new scientific direction.

## References

- [1] Truslyakov V, Blesman A, Russkikh G, etc 2021 *Development of polymer composite materials and structures with their subsequent utilization after the mission* (Journal of Physics Conference Series) **Vol 1901** DOI 10.1088/1742-6596/1901/1/012099
- [2] Trushlyakov V, Zharikov K, Davydovich D 2019 *Combustion possibility assessment for separating launch-vehicle components during atmospheric phase of descent trajectory* (Acta Astronautica) **Vol 159** pp 540–546 DOI: 10.1016/j.actaastro.2019.02.003
- [3] Dreus A, etc 2021 *A simulation of the thermal environment of a plastic body of a new type of launch vehicle at the atmospheric phase of the trajectory* (Aircraft Engineering and Aerospace Technology) DOI 10.1108/AEAT-04-2021-0100
- [4] Monogarov K, etc 2016 *Uncontrolled re-entry of satellite parts after finishing their mission in LEO: Titanium alloy degradation by thermite reaction energy* (Acta Astronautica) **Vol 135** pp 69–75
- [5] Monogarov K, etc 2018 *Utilization of thermite energy for re-entry disruption of detachable rocket elements made of composite polymeric material* (Acta Astronautica) **Vol 150** pp 49 – 55
- [6] Fedorov A V 2012 *Fundamentals of rocket-space complexes* 243 p
- [7] OST 92-5156-90 1991 *Three-layer structures with laminated polymer composite materials shells* 37 p
- [8] Truslyakov V, etc *Rocket head fairing* Patent Russia no 2581636
- [9] Lempert D, etc 2015 *Estimation of mass of pyrotechnic mixture for space rocket payload fairing combustion* (Physics of Combustion and Explosion) **Vol 51** pp 121-125
- [10] Zarko V, etc 2016 *Preliminary assessment of the possibility of using mechanically activated pyrotechnic compositions for combustion of composite materials* (Dynamics of systems, mechanisms and machines) **Vol 3** pp 252-257
- [11] Panichkin A, Truslyakov V, Iordan Yu *Program for calculating the geometric parameters of the filler charge design of the combustible demonstrator. The "complicated rectangular channel" form* Computer program no 2020661061
- [12] Panichkin A, Truslyakov V, Iordan Yu *Program for calculating the geometric parameters of the filler charge design of the combustible demonstrator. The "rectangular channel" form* Computer program no 2020661093
- [13] Panichkin A, Truslyakov V, Iordan Yu *Program for calculating the geometric parameters of the filler charge design of the combustible demonstrator. The "triangular channel" form* Computer program no 2020661094
- [14] Trushlyakov V, Panichkin A 2021 *Methodology for the Design of Combustible Structures of Separating Launch Vehicle Parts* (Journal of Spacecraft and Rockets) DOI: 10.2514/1.A34920
- [15] Truslyakov V, Blesman A, Russkikh G, Davydovich D, Mikhailovskiy K 2018 *Development of composition and manufacturing technology, combustible polymer composite material* (Proceedings of functional nanomaterials and high-purity substances) pp 159–161

## Acknowledgments

The work was carried out with the financial support of the state assignment of the Ministry of Science and Higher Education No. 2019-0251 of 02.03.2020.

The author thanks the scientific supervisor, doctor of technical Sciences, Professor Trushlyakov Valery Ivanovich.